

Set of tungsten carbide rotary burrs in plastic case

Description	Part no.
Display of tungsten carbide rotary burrs in a convenient table display 35pcs each 1 x Ø 6.0 - 8.0 - 10.0 - 12.0 - 16.0mm Shape A cylinder (ZYA) with end tothing Shape A cylinder (ZYA) without end tothing Shape C sphero-cylindrical (WRC) Shape D cone (KUD) Shape F full arch (RBF) Shape G pointed arch (SPG) Shape M pointed cone (SKM)	R116008

Description	Part no.
Ruko Rotary Burr Set	RA116001

Description	Part no.
Set of tungsten carbide rotary burrs 10-piece 2 Rotary burrs shape A cylinder (ZYA) without end tothing Ø D1 10.0mm + Ø D1 12.0mm 2 Rotary burrs shape C oval (WRC) Ø D1 10.0mm + Ø D1 12.0mm 2 Rotary burrs shape G tree (SPG) Ø D1 10.0mm + Ø D1 12.0mm 2 Rotary burrs shape F ball nose tree (RBF) Ø D1 10.0mm / Ø D1 12.0mm 1 Rotary burr shape M cone (SKM) Ø D1 12.0mm 1 Rotary burr shape D Ball type (KUD) Ø D1 12.0mm	R116003



Tungsten carbide rotary burrs shape A cylinder (ZYA) without end tothing

Finish: Shape A cylinder (ZYA) Tothing: CT4
 without end tothing Surface: bright

Cutting: Cross tothing

The high-performance tungsten carbide rotary burrs provide maximum cutting edge stability with a simultaneous high tenacity of the cutting edge. The cross tothing provides a higher cutting capacity compared with the simple tothing. This particularly has a positive effect on materials which are difficult to cut.

Fields of application: for high-alloy steels, non-rusting steels, acid resistant steels, heat-resistant steels, die-casts and plastics. To de-bur, break edges, trim, process welding seams, surface processing.

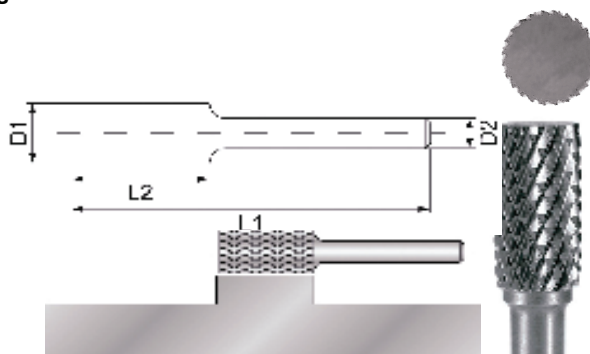

Ø-D1 mm	L2 mm	Total length L1 min. mm	Shank - Ø D2 mm	Part no.
6	18	58	6	R116010
8	18	60	6	R116011
10	20	60	6	R116012
12	25	65	6	R116013
16	25	65	6	R116014

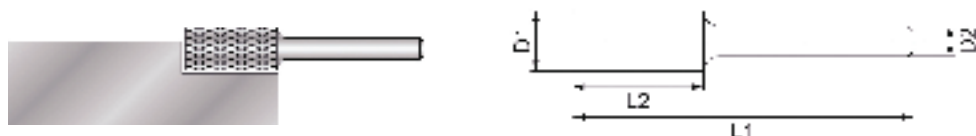

Ø-D1 mm	L2 mm	Total length L1 min. mm	Shank - Ø D2 mm	Part no.
6	18	58	6	R116015
8	18	60	6	R116016
10	20	60	6	R116017
12	25	65	6	R116018
16	25	65	6	R116019



Tungsten carbide rotary burrs shape C oval (WRC)

Finish: Shape C oval (WRC)
 Cutting: Cross tothing
 Tothing: CT4
 Surface: bright

Packing unit:
 each in plastic packaging

The high-performance tungsten carbide rotary burrs provide maximum cutting edge stability with a simultaneous high tenacity of the cutting edge. The cross tothing provides a higher cutting capacity compared with the simple tothing. This particularly has a positive effect on materials which are difficult to cut.

Fields of application: for high-alloy steels, non-rusting steels, acid resistant steels, heat-resistant steels, die-casts and plastics. To de-bur, break edges, trim, process welding seams, surface processing.

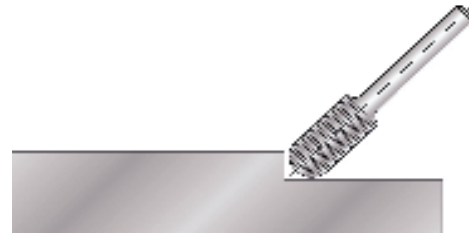
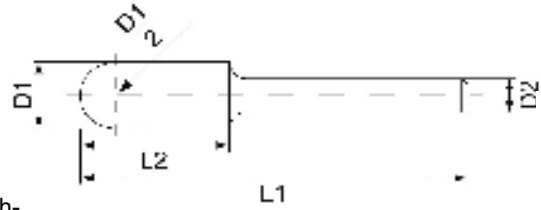

Ø-D1 mm	L2 mm	Total length L1 min. mm	Shank - Ø D2 mm	Part no.
6	18	58	6	R116020
8	18	60	6	R116021
10	20	60	6	R116022
12	25	65	6	R116023
16	25	65	6	R116024

Tungsten carbide rotary burrs shape G tree (SPG)

Finish: Shape G tree (SPG)
 Cutting: Cross tothing
 Tothing: CT4
 Surface: bright

Packing unit:
 each in plastic packaging

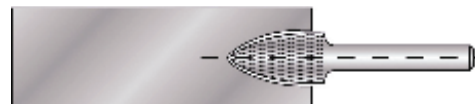
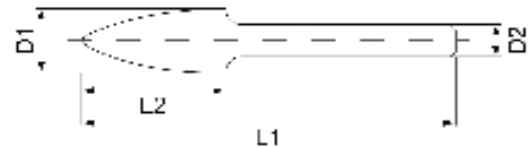

Ø-D1 mm	L2 mm	Total length L1 min. mm	Shank - Ø D2 mm	Part no.
6	18	58	6	R116025
8	18	60	6	R116026
10	20	60	6	R116027
12	25	65	6	R116028
16	25	65	6	R116029

Tungsten carbide rotary burrs shape F ball nose tree (RBF)

Finish: Shape F ball nose tree (RBF)
 Cutting: Cross tothing
 Tothing: CT4
 Surface: bright

Packing unit:
 each in plastic packaging

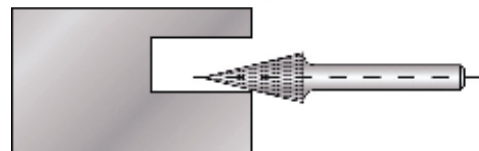
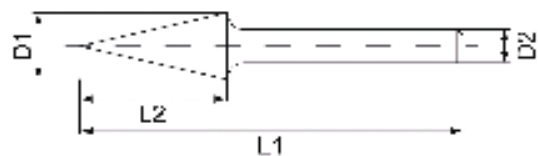

Ø-D1 mm	L2 mm	Total length L1 min. mm	Shank - Ø D2 mm	Part no.
6	18	58	6	R116030
8	18	60	6	R116031
10	20	60	6	R116032
12	25	65	6	R116033
16	25	65	6	R116034

Tungsten carbide rotary burrs shape M cone (SKM)

Finish: Shape M Cone (SKM)
 Cutting: Cross tothing
 Tothing: CT4
 Surface: bright

Packing unit:
 each in plastic packaging

The high-performance tungsten carbide rotary burrs provide maximum cutting edge stability with a simultaneous high tenacity of the cutting edge. The cross tothing provides a higher cutting capacity compared with the simple tothing. This particularly has a positive effect on materials which are difficult to cut.

Fields of application: for high-alloy steels, non-rusting steels, acid resistant steels, heat-resistant steels, die-casts and plastics. To de-bur, break edges, trim, process welding seams, surface processing.

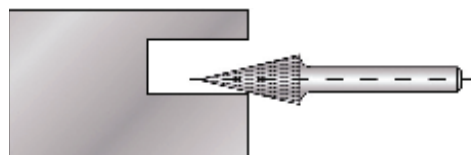
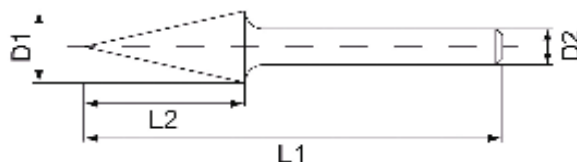

Ø-D1 mm	L2 mm	Total length L1 min. mm	Shank - Ø D2 mm	Part no.
6	18	58	6	R116035
8	18	60	6	R116036
10	20	60	6	R116037
12	25	65	6	R116038
16	25	70	6	R116039

Tungsten carbide rotary burrs shape D ball type (KUD)

The high-performance tungsten carbide rotary burrs provide maximum cutting edge stability with a simultaneous high tenacity of the cutting edge. The cross tothing provides a higher cutting capacity compared with the simple tothing. This particularly has a positive effect on materials which are difficult to cut.

Fields of application: for high-alloy steels, non-rusting steels, acid resistant steels, heat-resistant steels, die-casts and plastics. To de-bur, break edges, trim, process welding seams, surface processing.

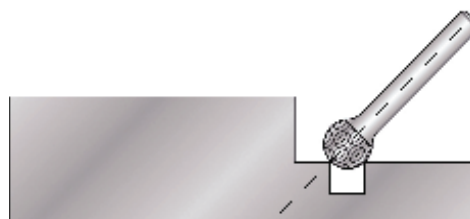

Finish: Shape D ball type (KUD)
 Cutting: Cross tothing
 Tothing: CT4
 Surface: bright

Packing unit:
 each in plastic packaging



Ø-D1 mm	L2 mm	Total length L1 min. mm	Shank - Ø D2 mm	Part no.
6	18	58	6	R116041
8	18	60	6	R116042
10	20	60	6	R116043
12	25	65	6	R116044
16	25	65	6	R116045